

UNMATCHED PERFORMANCE



## AFK-SERIES NC ROLL FEEDER

Featuring Oriimec's original all-new G-Type CCS controller, the AFK roll feeder is designed for easy handling of small width coils. Outfitted with a solid aluminum body, this machine gives a high degree of rigidity to the finished product. Installation is easy, with two T-bolts on bolster.



### Other Features:

- Easy roll opening adjustment by dial selector
- Servomotor with brake to hold coiled material
- Roll release (pilot release) is standard and can keep up with the press at speeds up to 200 strokes per minute.

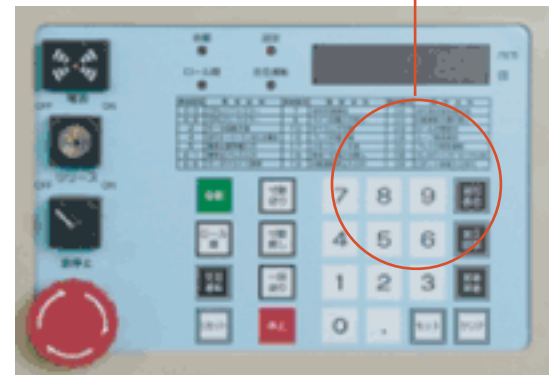
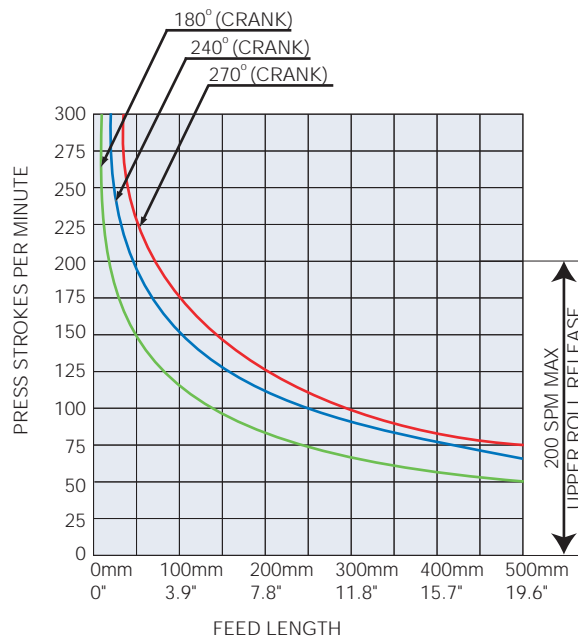

The liquid crystal panel and NC system make programming the feed lengths quick and easy. Controls are pedestal mounted on the U.S. version.

An industry leader in pressroom automation for more than 30 years, Oriimec provides robots, transfer systems, coil handling equipment and straightener/feeder combination units to customers worldwide. Manufactured in Japan, the Orii line of equipment is engineered to meet the specific needs of each of our customers. All Orii products sold in the U.S. are paired with expert service and technical support from our Erlanger, KY office.

UNMATCHED PERFORMANCE



# AFK-SERIES NC ROLL FEEDER

|                  | AFK02                   | AFK03                    |
|------------------|-------------------------|--------------------------|
| Coil Width       | 20-200 mm (0.78"-7.87") | 20-300 mm (0.78"-11.81") |
| Coil Thickness   | ~2.3 mm (~0.090")       |                          |
| Roll Length      | 220 mm (8.66")          | 320 mm (12.59")          |
| Roll Pressure    | Air and Spring          |                          |
| Roll Lift        | Air                     |                          |
| Motor            | AC 0.4kw                |                          |
| Repeatability    | ±0.2 mm (±0.007")       |                          |
| Pass Line Height | 70-170mm (2.75"-6.69")  |                          |
| Entry Guide      | Thumb Screw             |                          |
| Motor Power      | AC200/220V 50Hz/60Hz    |                          |
| Roll Lift        | MAX 200 SPM             |                          |

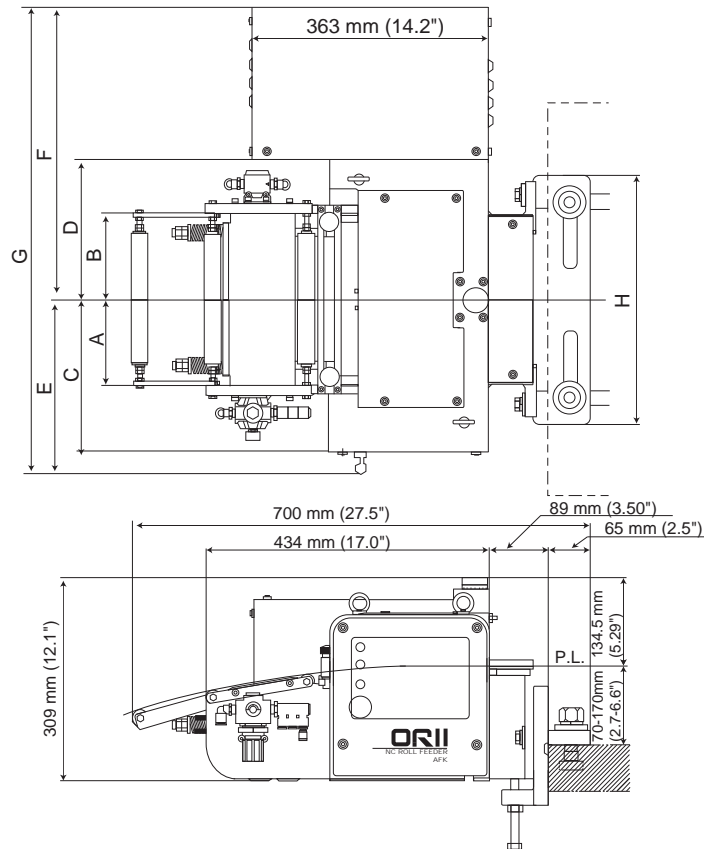

|   | AFK-02           | AFK-03            |
|---|------------------|-------------------|
| A | 131.5mm<br>5.17" | 181.5mm<br>7.14"  |
| B | 131.5mm<br>5.17" | 181.5mm<br>7.14"  |
| C | 234mm<br>9.21"   | 284mm<br>11.18"   |
| D | 213.5mm<br>8.40" | 263.5mm<br>10.37" |
| E | 268mm<br>10.55"  | 318mm<br>12.51"   |
| F | 445mm<br>17.51"  | 495mm<br>19.48"   |
| G | 713mm<br>28.07"  | 813mm<br>32.00"   |
| H | 380mm<br>14.96"  | 480mm<br>18.89"   |



Oriimec Corporation of America  
1840 Airport Exchange Blvd. #200  
Erlanger, KY 41018  
U.S.A

Phone:  
888.746.3320 (toll free)

Tel: 859.746.3318  
Fax: 859.746.3319  
Email: info@oriimec.com  
Website: www.oriimec.com

THE SOLUTIONS LEADER IN THE METAL AND WIRE FORMING INDUSTRIES